

SEAMING

INTRODUCTION

This bulletin addresses seaming Corian® Solid Surface.

OVERVIEW

High quality seams are essential to maximize the appearance and performance of Corian® Solid Surface installations. Tight seams with well prepared edges will result in inconspicuous seams except for select sheet aesthetics. Well placed and properly reinforced seams will ensure durability.

A. EDGE PREPARATION

When seaming two pieces of Corian® Solid Surface, it is important that the two pieces are a perfect fit. The quality of a seam is determined by how well the material fits together.

The ideal preparation for two edges to be seamed is the router pull-through method (Mirror Cut). This method entails using a standard double-fluted router bit that is passed simultaneously across the leading edges of both pieces of the Corian® Solid Surface to be seamed, as illustrated below.

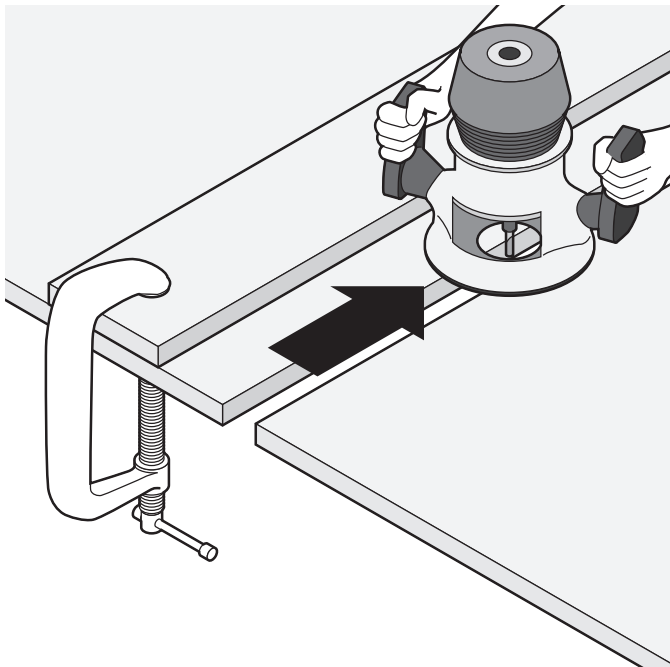

Figure A-1: Router Pull-Through Method (Mirror Cut)

Tools Required:

- 3-hp router
- Double-fluted 1/2" (13 mm) shank router bit
- C-clamps, 6" (152 mm) bar clamps
- Straightedge or mirror template

Steps to completion:

1. Place the two pieces to be seamed on a level workbench supported in a manner similar to that used when completing a cutout, to ensure that the router bit has a clean run.
2. Clamp the two pieces so that they are 3/8" (10 mm) apart and firmly and squarely affixed with clamps. It is imperative that the surfaces be parallel and in the same plane.
3. Attach the straightedge to one side to guide the router between the two sheets. As the blade of the router is 1/2" (13 mm), 1/16" (1.5 mm) will be removed from each edge and a perfect match will be created between the two pieces.

Be sure that the router handles clear the clamps before starting.

4. Remove the sheet labels in the vicinity of the seam on the side and back of sheets and any contamination that may discolor the seam. Use a clean, white cloth or white paper towel soaked in clear, denatured alcohol¹.

It is important to use white cloths or paper towels. The alcohol may extract colorants if present, discoloring the seam.

Always follow manufacturer's safety directions when handling and using denatured alcohol.

5. Trial-fit both edges to check for perfect fit.

¹Denatured alcohol is the preferred solvent for cleaning Corian® Solid Surface products. Acetone is approved for cleaning in regions where denatured alcohol is prohibited. Please see *Corian® Solid Surface Fabrication/Installation Fundamentals – Approved Cleaning Solvents (K-25701)* for more details.

SEAMING

HELPFUL HINTS

Do not touch the sharp edges once they are clean and ready for seaming.

Edge preparation for all seams (including on-site seams) should be done under factory conditions wherever possible.

Close attention to detail will help ensure a quality seam and avoid expensive rework.

Be sure that pieces are color matched before starting seam preparation.

Be sure that veined or metallic sheets are aligned appropriately before starting seam preparation.

B. BUTT SEAMS

A butt seam is used to describe any seam where Corian® Solid Surface is seamed edge-to-edge to make a single flat surface.

Seam Reinforcement Guidelines

Due to improvements in adhesive formulations, guidelines on seam reinforcement have changed.

- Seam reinforcements are *required* when using DuPont™ Joint Adhesive for all horizontal applications.
- Seam reinforcements are *suggested but not required* when using DuPont Joint Adhesive 2.0 for horizontal applications in general dry residential and commercial applications.
- Seam reinforcements are *not required* when using Corian® Joint Adhesive for horizontal applications in general dry residential and commercial applications.

Specialty applications may have different guidelines. For example, Food Service would require seam reinforcement for all adhesives where heavy equipment may be placed on the scene or near hot/wet applications such as heat lamps or hot food wells.

Steps to completion:

1. Complete edge preparation as per “Steps to completion” in Section A.
2. Transport pieces to be seamed to the workbench and lay out on a flat bench large enough to accommodate the pieces to be seamed.
3. Place a strip of plastic tape under the seam to stop surplus adhesive from spilling onto workbench.
4. Wipe both edges with a clean, white cloth soaked in clear, denatured alcohol.
5. Adjust the sheets from underneath until face alignment is perfect.
6. When the pieces to be seamed are perfectly clean, have good face alignment and good edge fit, prepare the DuPont™ Joint Adhesive, DuPont™ Joint Adhesive 2.0, or Corian® Joint Adhesive cartridge. Full instructions may be found in *Corian® Fabrication/Installation Fundamentals –Adhesives* (K-25290).

7. Set the two pieces to be seamed about 1/8" (3 mm) apart.
 8. Dam the ends of the two sheets using plastic release tape to prevent any adhesive from seeping from the ends of the seam.
 9. Push pieces together firmly by hand until uniform squeeze-out of adhesive is visible along the entire seam.
 10. Squeeze the DuPont™ Joint Adhesive, DuPont™ Joint Adhesive 2.0, or Corian® Joint Adhesive into the gap between the sheets. Fill the gap 1/3 to 1/2 full.
 11. Secure seam using a vacuum clamp system or glue small blocks of plywood to each piece with hot-melt glue, and clamp onto these with C-clamps or 6" (152 mm) bar clamps to provide seam pressure.
 12. Check to see that an even bead of adhesive is squeezed from the full length of the seam when pressure is applied.
 13. When the adhesive is completely set and hard, remove excess adhesive with a router on “skis.” Where “dustless” conditions are needed, use a block plane set on a low angle or a random orbital sander equipped with a vacuum. At the back of the countertop use a broad, sharp chisel if access with a block plane is impossible.
- Never remove excess adhesive with a belt sander as this will overheat the seam causing possible weakness, discoloration or failure of the joint.**

HELPFUL HINTS

Ensure that the sharp corners have been rounded on the chisel and plane blades to avoid scratching or gouging the surface when removing surplus adhesive.

Use the recommend DuPont™ Joint Adhesive, DuPont™ Joint Adhesive 2.0, or Corian® Joint Adhesive color for the best color match.

Never attempt any seam that is not a proper fit and is not thoroughly cleaned and color-matched.

Do not apply too much pressure to the seam as this may squeeze out all of the adhesive and weaken the joint.

There are several commercially available devices to aid in edge alignment. Some will even aid in pulling and holding the pieces together while the adhesive cures.

REINFORCED SEAMS

Deck seams in horizontal installations of Corian® Solid Surface may have to be reinforced as per the guidelines provided in Section B. The entire process may be done with the sheets upside down. When upside down, the edges, the seam reinforcement, reinforcement blocks and Corian® sinks or lavatories may be adhered at the same time.

To reinforce a seam, a 2" - 3" (51 - 76 mm) strip of Corian® Solid Surface is adhered centered under the seam in the deck. The strip must go the full length of the seam, as illustrated on the following page. Ensure strip is chip free.

SEAMING

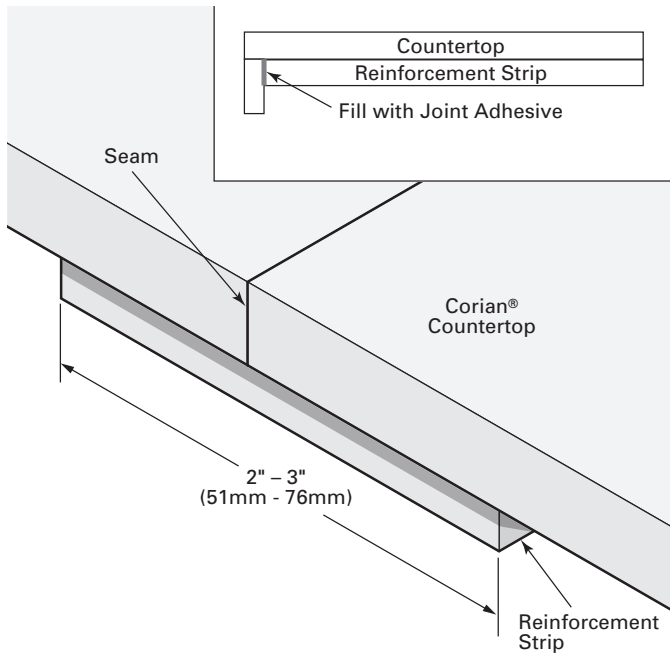

Figure C-1: Reinforcement strip runs from edge buildup strip to back of top

Apply adhesive to the end of the reinforcement strip which butts into the front edge buildup strips.

Steps to completion:

1. Remove excess adhesive and sand the underside of the sheet smooth. Wipe with denatured alcohol and clean white cloth.
2. Prepare the strips, making sure they are the same length as the seam (i.e., that they run the full length of the seam), and that they are between 2" (50 mm) and 3" (75 mm) wide.

The strip must be fully covered with DuPont™ Joint Adhesive, DuPont™ Joint Adhesive 2.0, or Corian® Joint Adhesive

3. Sand the strips prior to attachment to eliminate nicks and tool marks that could act as a stress-riser for cracks. Wipe strip with denatured alcohol and clean white cloth.
4. Apply a liberal amount of DuPont™ Joint Adhesive, DuPont™ Joint Adhesive 2.0, or Corian® Joint Adhesive to both surfaces and apply the strip evenly placed over the seam. Make sure there are no voids or dry areas (i.e., the adhesive must be spread evenly over the entire strip). Be sure the end of strip touching buildup strip is coated with adhesive. In addition, smooth all excess adhesive evenly on the underside of the seam along the edges of the reinforcement strip leaving a small cove.
5. Lightly clamp the strip to prevent movement while the adhesive cures.

6. The reinforcing strip may stick out past the back of the deck during seaming, but must be trimmed flush after the adhesive is completely set.

HELPFUL HINTS

Tests show that a reinforced seam is as strong as the material with no seam.

Do not reinforce a seam with material thinner than the countertop material. For example, do not reinforce 1/2" (12 mm) with 1/4" (6 mm) Corian® strips. However, 1/2" (12 mm) may be "reinforced" using 3/4" (19 mm) Corian® strips.

It is not essential to use the same color material or adhesive for reinforcing strips, but do not use dark color reinforcement strips with a light color sheet since the contrast may cause a shadow under the Corian® countertop material.

D. WAVY SEAMS

Another seam preparation technique is using the wavy cutter. Wavy seams may prove useful when seaming small pieces such as baseboards or chair rail. Wavy seams still require reinforcement in all horizontal applications.

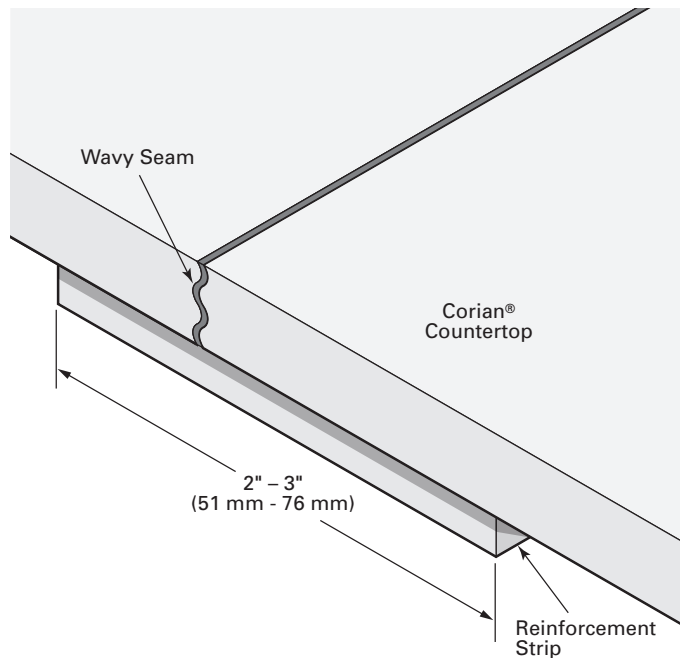

Figure D-1

Steps to completion:

1. Complete Edge Preparation as per "Steps to completion" in Section A.
2. Transport pieces to be seamed to the workbench and lay out on a flat bench large enough to accommodate the pieces to be seamed.

SEAMING

3. Work from the face side of one of the sheets to be seamed and set the wavy cutter to a depth that will pass through the thickness of the sheet while setting the center of one of the “waves” at the surface of the sheet. Set a straightedge parallel to the seam, which will allow the wavy bit to cut the wavy pattern into the edge.
4. Take the opposite edge to be seamed and again work from the face side of the sheet but this time lowering the cutter to the correct depth (check with bit manufacturer). This enables the two top surfaces to align flush to each other on the face side.
5. Alternatively, the wavy cutter can be used to mirror cut the two sheets to be seamed. One sheet must be lower than the other at the correct height (check with bit manufacturer). Trial-fit a smaller piece of Corian® Solid Surface to determine correct fit prior to making your actual seam.
6. Wipe both edges with a clean, white cloth soaked in clear, denatured alcohol.
7. Make seam as instructed in Section B.

E. TONGUE-AND-GROOVE SEAMS

The Tongue-and-Groove Seam is another modification to the Standard Seam by using a tongue and groove to enhance the face fit of the adjoining sheets. This can be used for 1/4" (6 mm) Corian® sheet very successfully.

The method can be used to save time on face sanding because the face is well leveled.

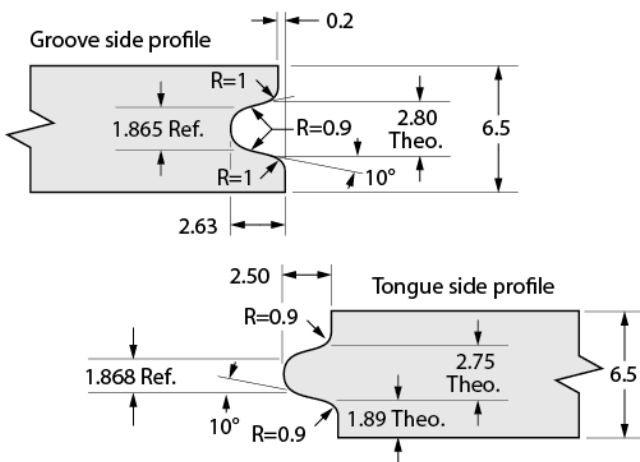

Note: Tongue-and-groove seams should have rounded internal angles, and be no less than 1/16-inch (1.5 mm).

Figure E-1

Bits can be custom-made, or several types are commercially available.

F. LEVELING SEAMS

A simple way to take out warp at the seam and level the top surfaces to be seamed is to use the Bridge Technique.

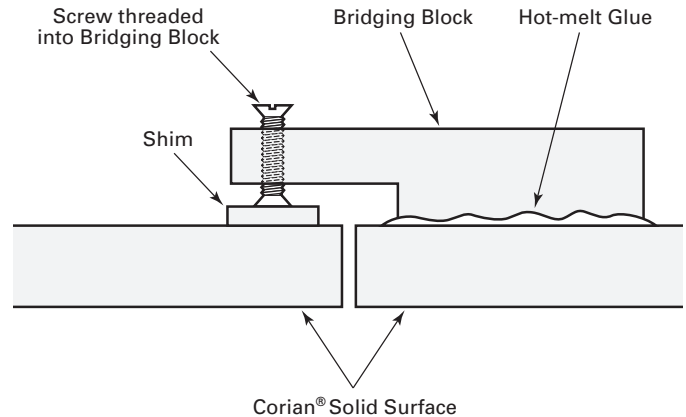

Figure F-1

Glue a bridging block to the lower side of the countertop seam using hot-melt glue. Carefully turn the screw in the bridging block until both surfaces are level. Bring together and adhere as normal. After completion, remove the block.

Protect countertop by using a wood or laminate shim under the screw.

G. V - GROOVE SEAMS

Requirements for seams made in V-groove tops are different than those for regular tops. The table below outlines the requirements for seams in V-groove tops.

Table G-1

| Procedure | Requirement |
|-----------------------------|--|
| Turndown on edge of seam | 1½" (38 mm) minimum |
| Turndown edge in seam area | ½" x ½" (12 mm x 12 mm) strip adhered behind front edge |
| Inside corner radius | Insert block—1" (25 mm) minimum |
| Butt seam at inside corner | Does not require reinforcement |
| Miter seam at inside corner | Must be reinforced |
| Deck seam | Completely filled with DuPont™ Joint Adhesive, DuPont™ Joint Adhesive 2.0, or Corian® Joint Adhesive |

Steps to completion:

1. All edges on the countertop sections to be seamed are to be turned down a minimum of 1½" (38 mm).
2. A reinforcing strip ½" x ½" (12 mm x 12 mm) x length of deck seam must be adhered in the inside corner between the deck and the front edge strip. This can be done as the edge is being assembled. This is only done in the area of the deck seam. The ½" x ½" (12 mm x 12 mm) strips should run from the front edge strip to the back of the deck.
3. Adhere end of one strip to the back of the front edge. Run other piece 1" (25 mm) past the insert block. Taper the end to 45°. See figure below.

An alternative to using a ½" x ½" (12 mm x 12 mm) strip is to make the strips ½" (12 mm) x the full height of the turned down edge piece. This will ensure adequate material will be left if the seam edges must be trimmed.

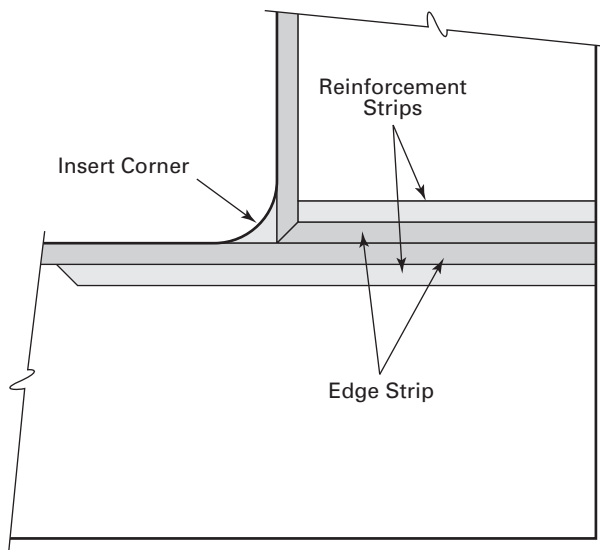

Figure G-1: View from Underside of Corian® Countertop

Seam Preparation

The edges of the seam are to be smoothed using typical methods such as the Mirror Cut technique. Since the two deck pieces are joined without an offset seam, the insert method must be used to make the inside corner radius. See *Corian® Solid Surface Fabrication/Installation Fundamentals – Edge Details and Buildups* (K-25293).

An alternative method is to partially remove some of the front edge and inlay the corner block into the edge. There are several manufacturers who make special templates for this purpose.

A seam made with edges turned down by the V-groove method does not require seam reinforcement. However, if the inside corner is mitered, then reinforcement is mandatory.

H. MITER SEAMS

Several of the colors of Corian® Solid Surface have a pattern or directional aesthetic. A typical butt seam does nothing to change of direction of the pattern. In these cases, a miter seam may give the best aesthetics by allowing the patterns to “flow” through the corner. A miter seam does not give the best yield of the material as there are two triangular pieces left from making the miters. Pieces can be used to make reinforcement blocks, or short edge strips.

When using a miter seam, all requirements for a deck seam must be followed.

When making a miter seam, use the insert block method to get the proper inside corner radius. This combined with two blocks, which are attached to the underside of the deck in the corner, makes for a very strong seam. However, this requires that the reinforcement strip fits against the backside of the first block as shown below. There are several ways to accomplish this including:

- Cut a square notch in the reinforcement strip.
- Rout the notch in the reinforcement strip and round the back corner of the block.
- Square off the back corner of the block to make a butt seam.

Be sure the joint between the reinforcement strip and the corner block is completely filled with adhesive.

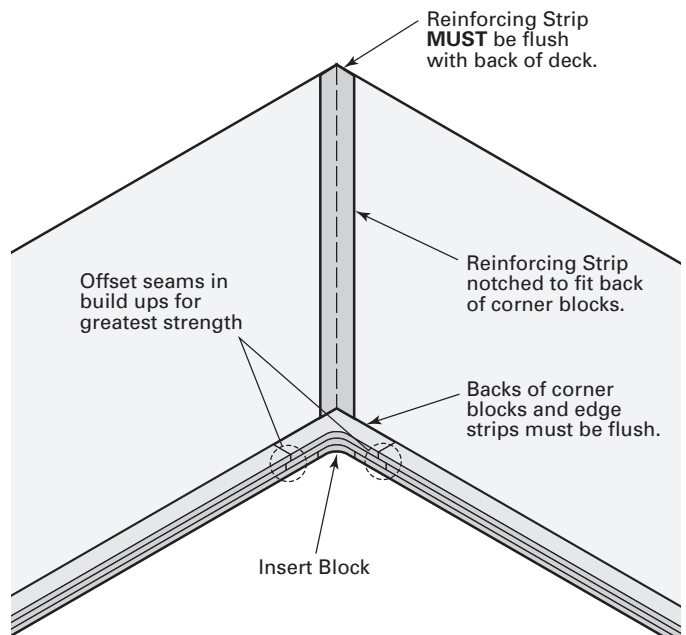

Figure H-1: View of inside corner from the underside of the top

SEAMING

Offsetting the seams in the corner blocks will help strengthen the corner. When using a drop edge, a different method is used for the inside corner to assure a strong corner.

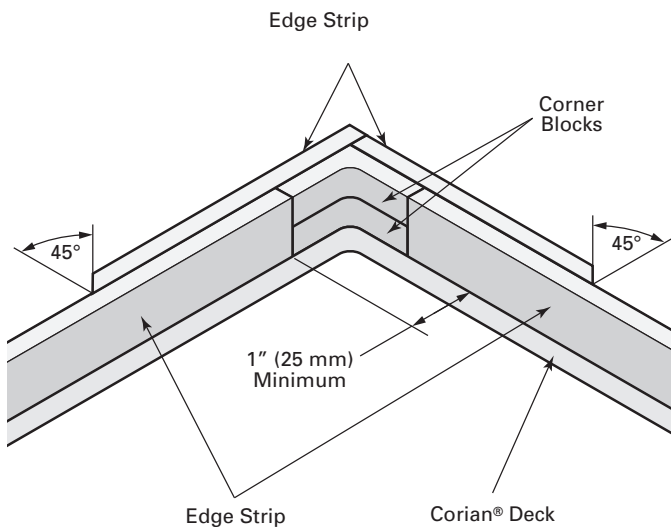

Figure H-2

The strips extending from the corner blocks should be at least 3" (76 mm) long and must be fully adhered using joint adhesive.

I. SEAMING FROM A PANEL SAW

When cut properly with high quality equipment, sheets may be seamed directly, without performing a router mirror cut. The quality of saw cut seams will vary with:

- Rigidity of the saw
- Saw set-up
- Blade life
- Cut speed
- Skill of the operator.

To obtain the highest quality of cut:

- Use saw with sufficient mass and rigidity.
- Make sure the saw is properly set up for Corian® Solid Surface (blades, feed rate, etc.)
- Use the saw blade manufacturer's recommended blade speed and cut rate.
- Make a smooth transition when entering and exiting material.

Confirm cut quality by cutting some left-over material and examining the test cut, it should be clean, square, and free of any chips. On initial saw set up it is advisable to seam and finish the test material to visually confirm seam quality.

J. REFERENCED DOCUMENTS

Corian® Solid Surface Fabrication/Installation Fundamentals – Adhesives (K-25290)

Corian® Solid Surface Fabrication/Installation Fundamentals – Edge Details and Buildups (K-25293)

Corian® Solid Surface Fabrication/Installation Fundamentals – Approved Cleaning Solvents (K-25701)

This information is based on technical data that E.I. du Pont de Nemours and Company and its affiliates ("DuPont") believe to be reliable, and is intended for use by persons having technical skill and at their own discretion and risk. DuPont cannot and does not warrant that this information is absolutely current or accurate, although every effort is made to ensure that it is kept as current and accurate as possible. Because conditions of use are outside DuPont's control, DuPont makes no representations or warranties, express or implied, with respect to the information, or any part thereof, including any warranties of title, non-infringement of copyright or patent rights of others, merchantability, or fitness or suitability for any purpose and assumes no liability or responsibility for the accuracy, completeness, or usefulness of any information. This information should not be relied upon to create specifications, designs, or installation guidelines. The persons responsible for the use and handling of the product are responsible for ensuring the design, fabrication, or installation methods and process present no health or safety hazards. Do not attempt to perform specification, design, fabrication, or installation work without proper training or without the proper personal protection equipment. Nothing herein is to be taken as a license to operate under or a recommendation to infringe any patents. DuPont shall have no liability for the use of or results obtained from such information, whether or not based on DuPont's negligence. DuPont shall not be liable for (i) any damages, including claims relating to the specification, design, fabrication, installation, or combination of this product with any other product(s), and (ii) special, direct, indirect or consequential damages. DuPont reserves the right to make changes to this information and to this disclaimer. DuPont encourages you to review this information and this disclaimer periodically for any updates or changes. Your continued access or use of this information shall be deemed your acceptance of this disclaimer and any changes and the reasonableness of these standards for notice of changes.

Copyright© 2018 E. I. du Pont de Nemours and Company. The Corian® Design Logo and Corian® are trademarks of E. I. du Pont de Nemours and Company or its affiliates. All rights reserved.