

METALLIC AESTHETICS

INTRODUCTION

This bulletin addresses the procedures for fabricating DuPont™ Corian® solid surface colors with metallic aesthetics, including techniques to create unique aesthetics utilizing the directional nature of the product.

OVERVIEW

Corian® solid surface is available in three types of aesthetics with metallic reflectivity. There are five solid colors: Azurite, Bronzite, Copperite, Olivite, and Silverite. Three colors, Aqualite, Clove and Graylite, have particulates. Two additional colors, Basil and Sorrel, are also Private Collection colors that do not exhibit the behavior discussed here and should be fabricated in the same manner as other large scale pattern products.

The metallic pigments in the solid colors reflect light in a directional manner. Depending on the design goals, the objective may be to either maximize or minimize the directional effect relative to a reference point. For best visual results, you will need to consider directionality of the sheet, lighting type and locations from where observers will view the sheet, the impact on layout, and assembly techniques. This bulletin contains several design ideas to get you started. With experience, you will likely find additional techniques to maximize the beauty and visual activity of your installations. Be sure to show samples to your customer to ensure that the design will meet their expectations.

This bulletin focuses on the unique characteristics of these colors, especially the solid colors, as they have the strongest directional behavior. The particulate containing samples have similar behavior, but the particulates disrupt the pattern and it is not as distinctive. There are some differences which are discussed in the relevant sections. The focus is on fabrication techniques that are unique to these colors and assume an understanding of Corian® fabrication. All typical fabrication and installation requirements, seam reinforcement, for example, must be followed. For complete details of assembly procedures, refer to the *DuPont™ Corian® Solid Surface Fabrication/Installation Fundamentals* bulletins.

A. KEY DESIGN POINTS

This product is directional, both on the top surface and on the edges. It is best used when the directionality is highlighted. Creating uniform appearances is possible, but requires special attention to sheet orientation and not all standard fabrication techniques are applicable.

The reflectivity of sheet edges is not completely uniform. If a uniform edge profile is required, a v-groove edge is recommended.

The directional nature of the sheet must be accounted for during design and fabrication. This directionality persists through the thickness and is most apparent along the length of the sheet. If two sections are joined with different orientations so that they look different on the top surface, the edge profiles may also look different.

Using the orientation of the product back side labeling as a reference direction and marking all cut pieces with a directional arrow will help later with properly orienting the pieces during assembly. Otherwise, it may be difficult to visually determine orientation of the cut pieces until they are seamed together and the sample is finished.

Sheet Reflectivity

The metal flakes in the sheet are at a slight angle to the surface. The reflectivity of the sheet varies with orientation. This varying appearance is what makes the creative designs possible.

The sheet is most reflective looking towards 0° from the 180° position (the direction of the arrows on the backside label). The view of the 90° and 270° positions is slightly less reflective. The least reflective viewing angle is looking at 180° from the 0° position. This is true for both the top and any edge profiles. These statements assume uniform lighting. Directional lighting may change the visible appearance.

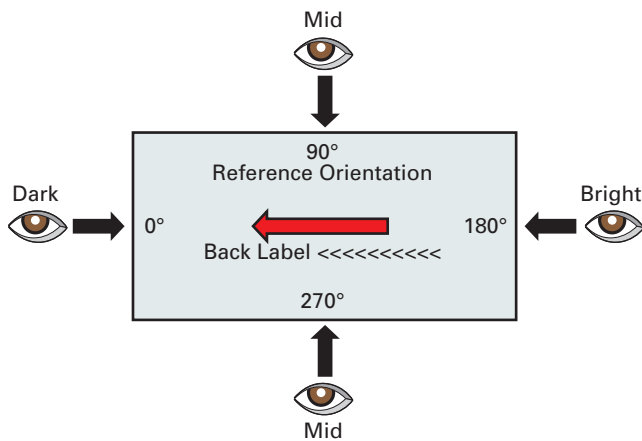

Figure D-1 - Effect of Orientation on Reflectivity

Lighting

Lighting plays a strong part in the visibility of patterns. Directional lighting can maximize visual effects when oriented in a way that maximizes directional reflections. Uniform area lighting may decrease the impact of the patterns. Directional lighting typically has a spot source, such as incandescent or halogen bulbs. An example of area lighting would be banks of fluorescent tubes. LED lighting can be either directional or area depending on the lighting design.

Creating “Disappearing” Designs

Creating patterns that are only visible from certain angles can be a creative design option. These designs “appear and disappear” as the observer viewpoint changes. Patterns are most likely to “disappear” (have a uniform appearance without pattern) if all components are oriented to either 0° or 180°. These patterns will be most visible looking down the 0° or 180° axes that align with the sheet orientations. They will be least visible from the 90° and 270° axes. This is illustrated in Figure D-2.

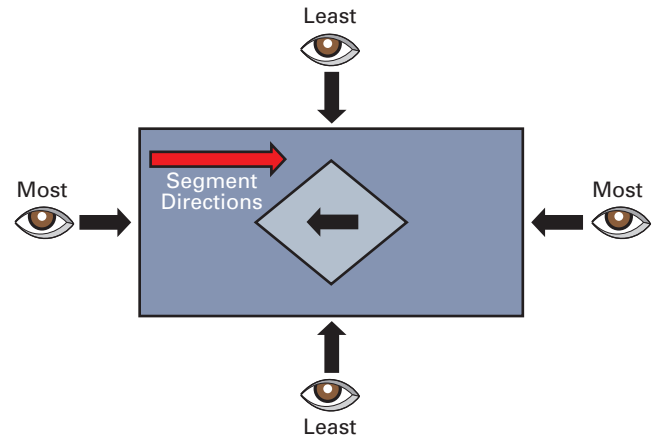

Figure D-2 - Creating “Disappearing” Patterns

Creating Aesthetics Visible from Many Angles

Patterns will be visible from more angles if sections are oriented 90° from each other. They will be most visible looking along one of the original axes of the sheet. The patterns will be least visible looking from a point half way between the original axes when the sheets are oriented so that the label arrows are both pointing away or towards the observer. When the sheets are oriented so that one label arrow is pointing towards the viewer and one away, as in Figure D-3, the pattern will be moderately visible. This figure also illustrates the importance of the observer viewpoint. The same pattern may look very different from different observer viewpoints.

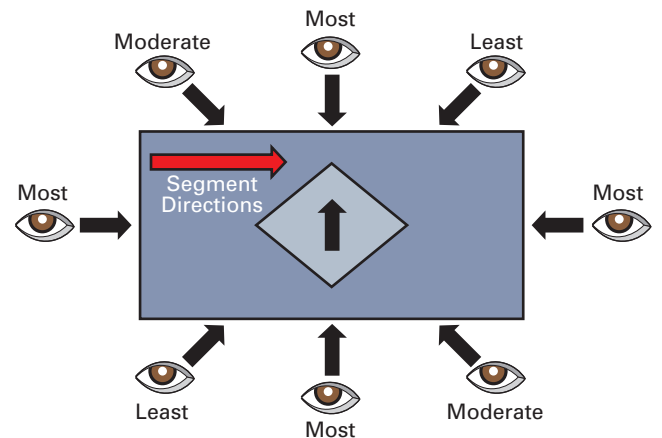

Figure D-3 - Creating Patterns Visible at Many Angles

E. DESIGNING TO MINIMIZE DIRECTIONAL EFFECTS

Trying to present a “uniform” appearance is more difficult than designing to take advantage of directional effects. The best way to achieve a uniform appearance is to assemble all pieces with the same orientation. Where this is unpractical, then the transition should look as natural as possible, often achieved with a mitered seam.

When designing to minimize directional effects, the arrows on the labels should be pointing so that they meet at some point. The directional effect will be least visible from a point midway between the two arrows, so the most likely position that people will view the design must be considered. This is shown in Figure E-1. The arrows are representative of the sheet orientation as defined by the directional arrows in the backside product label. The eye and arrow represent a viewer position and angle of observation.

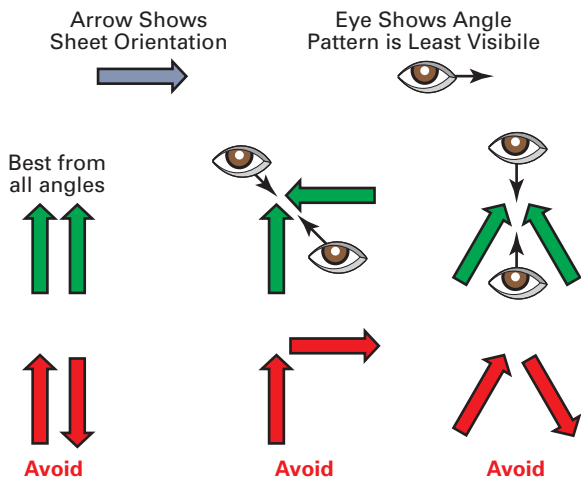

Figure E-1 - Designing to Minimize Directional Effects

F. SEAMS

Light reflection varies as the metallic colors are viewed from different angles. This can appear as a color difference when sheets are joined. Common examples of where sheets may come together at 90° angles are “L” or “U” shaped tops. This is a natural feature of the aesthetic and will be more evident in some colors and finishes than others. It is best to have samples to show the customer so it is understood what the final piece will look like.

Diagonally Seamed Corners

When two sheets need to be joined at an angle a diagonal seam will provide the best appearance. A diagonal seam will provide a subtle, neatly tailored change in directionality. This seam will be least noticeable looking down the diagonal and directly above. The seam is most visible looking down the length of the sheets at low angles.

The sheet orientations should be as shown in the “correct” example in Figure F-1, with the arrows in the backside label both pointing either towards the corner as in the diagram or both arrows pointing away from the corner. They should not meet in a head-to-tail orientation as shown in the “incorrect” example in F-1.

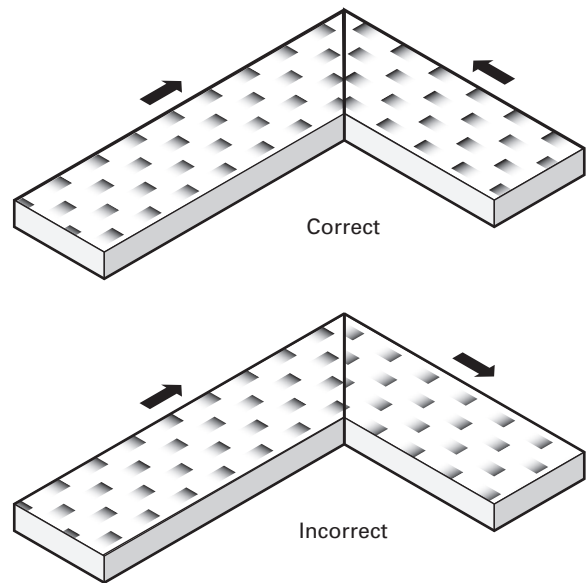

Figure F-1 - Diagonal Corner Seams

Offset-Seamed Corners

If one side of an “L” is less than 60 inches (152.4 cm) then a typical offset seam can be used at the corner. Additional 30 inch sections could be added, maintaining the common orientation as shown in Figure F-2.

The sheet orientations should be as below on the left, with the arrows in the backside label both pointing in the same direction.

See *DuPont™ Corian® Fabrication/Installation Fundamentals – Positioning of Seams* (K-25288) for more information

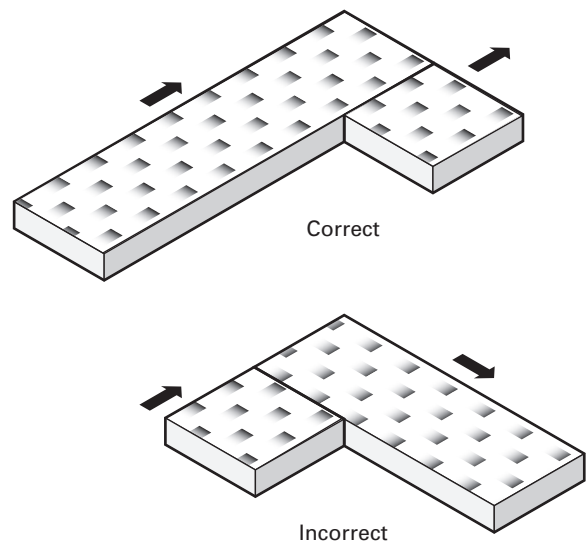

Figure F-2 - Offset Corner Seams

G. EDGE OR CORNER DETAILS

This section addresses options for corners or edges. The metallic colors have reflective metal flakes that are generally oriented in the plane of the sheet. Thus the edge of the sheet shows the edges of the metallic flakes. As the edges reflect less light compared to the surface of the flake, the edges of the sheet will have a darker, less reflective appearance. The orientation of the flakes changes through the thickness so the edge appearance has some variation in reflectivity which is most noticeable for flat stacked profiles. Creating a curved edge profile masks much of the non-uniformity. The reflectivity also varies with orientation of the sheet in the same manner as the top surface.

If a drop edge is used, the surface reflectivity of the vertical edge contrasts with the edge view of the top sheet. Therefore a more suitable aesthetic is obtained using a v-groove edge. A v-groove edge will give the most uniform appearance when a tight radius is used.

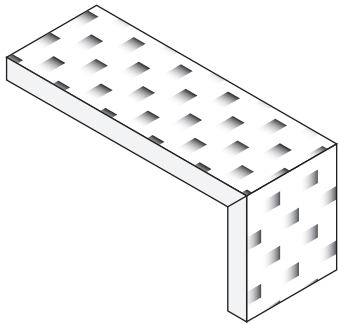

Figure G-1 - V-groove Edge

The appearance of a stacked edge does differ from the top appearance and there will be varying reflectivity on the edge. This is most apparent for a flat edge. If profiles are used, the change in reflectivity from the curvature hides some of the variation and the surface will look more uniform. The stacked sheets should have the same orientation as the top sheet. Different profiles (bullnose, ogee, etc.) will give different effects. A strip of a contrasting color will also hide the varying reflectivity.

Drop edges or a butt seam on a vertical corner are not recommended unless the visual contrast is desired. In all cases, having samples to show customers so they understand the visual details will help avoid surprises when the job is installed.

Particulate products: Particulates distort the metal flake orientation enough that the appearance of a stacked edge is more uniform. The behavior is the same as other

non-metallic products with large grinds in that while the face is sanded to reveal the large particulates, the back is not and large particulates are not exposed. If the stack is assembled with two sheets “back to back” the seam area may have a scarcity of large particles and appear non-uniform. For best appearance all strips in the stack should be assembled “face up”.

See *DuPont™ Corian® Fabrication/Installation Fundamentals – Edge Details and Buildups* (K-25293) for more information.

H. COVES

For metallic colors reflectivity varies with the orientation of the metallic flakes to the viewer. Creating the cove reveals the interior of the sheet, and the metal flakes will not be aligned with the surface cut of the cove. Depending on the angle of observation, the cove may match, but will tend to look darker than the horizontal or vertical surfaces surrounding it at other angles. This may be less visible for the particulate containing products, but is still there. Coves are therefore not recommended. If a cove is required, the v-groove technique provides the best cove, but it will be visible from some angles. Make sure the customer sees a sample and approves the appearance. Set-on or butt-seamed back splashes are recommended. See *DuPont™ Corian® Fabrication/Installation Fundamentals – Backsplashes* (K-25294) for more information.

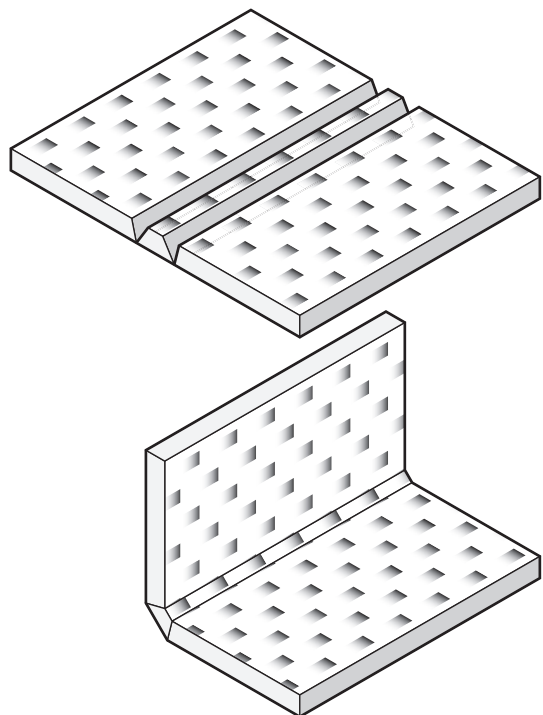

Figure H-1 - V-groove Cove

METALLIC AESTHETICS

I. THERMOFORMING

DuPont™ Corian® solid surface with metallic flake can be thermoformed using typical settings. Thermoforming behavior will be comparable to products similar in coloration without metallic flake. It is important to account for directionality during the design of the part and during fabrication. To track orientation it is best to put arrows on each piece indicating the orientation relative to the backside label. See *DuPont™ Corian® Fabrication/Installation Fundamentals – Thermoforming* (K-25297) for more information.

J. FINISHING

All typical finishing methods are suitable to use on Corian® Metallic colors. Darker colors may have a better appearance with a semi-gloss finish. As with other dark colors, the color will get darker and deeper with higher gloss finishes. The metallic flakes and directionality effects will also be more apparent at higher glosses. The consumer should be made aware of the proper care and maintenance instructions for the provided gloss level. The use of low angle lighting will help highlight scratches for removal. It also may be necessary to finish up with a finer than normal grit of abrasive. As always, cleaning the top between grit changes is needed. Buffing pads may turn dark from metal oxide removed during polishing.

The entire surface should have a uniform finish, paying particular attention to finishing after field seaming.

See *DuPont™ Corian® Fabrication/Installation Fundamentals – Finishing and Polishing* (K-25298) for more information.

K. SUMMARY

The directional nature of metallic flakes in these Corian® colors allows for some creative designs that change with viewing angle. When directionality is not desired many typical fabrication techniques can be used, but an awareness of the impact of sheet orientation on fabrication methods is required to minimize the effect of directionality. In addition, all requirements as set forth in Tech Bulletin, *DuPont™ Corian® Solid Surface Fabrication/Installation Fundamentals Requirements* (K-25705) must be followed.

L. REFERENCED DOCUMENTS

DuPont™ Corian® Fabrication/Installation Fundamentals – Positioning of Seams (K-25288)

DuPont™ Corian® Fabrication/Installation Fundamentals – Edge Details and Buildups (K-25293)

DuPont™ Corian® Fabrication/Installation Fundamentals – Backsplashes (K-25294)

DuPont™ Corian® Fabrication/Installation Fundamentals – Thermoforming (K-25297)

DuPont™ Corian® Fabrication/Installation Fundamentals – Finishing and Polishing (K-25298)

DuPont™ Corian® Fabrication/Installation Fundamentals – Requirements (K-25705)

This information is based on technical data that E.I. du Pont de Nemours and Company and its affiliates (“DuPont”) believe to be reliable, and is intended for use by persons having technical skill and at their own discretion and risk. DuPont cannot and does not warrant that this information is absolutely current or accurate, although every effort is made to ensure that it is kept as current and accurate as possible. Because conditions of use are outside DuPont’s control, DuPont makes no representations or warranties, express or implied, with respect to the information, or any part thereof, including any warranties of title, non-infringement of copyright or patent rights of others, merchantability, or fitness or suitability for any purpose and assumes no liability or responsibility for the accuracy, completeness, or usefulness of any information. This information should not be relied upon to create specifications, designs, or installation guidelines. The persons responsible for the use and handling of the product are responsible for ensuring the design, fabrication, or installation methods and process present no health or safety hazards. Do not attempt to perform specification, design, fabrication, or installation work without proper training or without the proper personal protection equipment. Nothing herein is to be taken as a license to operate under or a recommendation to infringe any patents. DuPont shall have no liability for the use of or results obtained from such information, whether or not based on DuPont’s negligence. DuPont shall not be liable for (i) any damages, including claims relating to the specification, design, fabrication, installation, or combination of this product with any other product(s), and (ii) special, direct, indirect or consequential damages. DuPont reserves the right to make changes to this information and to this disclaimer. DuPont encourages you to review this information and this disclaimer periodically for any updates or changes. Your continued access or use of this information shall be deemed your acceptance of this disclaimer and any changes and the reasonableness of these standards for notice of changes.

© E.I. du Pont de Nemours and Company 2012. All rights reserved.

The DuPont Oval, DuPont™, The Miracles of Science®, and Corian® are trademarks or registered trademarks of E.I. du Pont de Nemours and Company (“DuPont”) or its affiliates. K-25703 5/12